



Resa e Produzione più alte

Efficienza max 98.6%



Semplice e facile

Solo 17 kg



Predisposto per la batteria

Interfaccia Plug & Play per la batteria



Sicurezza e affidabilità

Protezione da guasto per arco elettrico

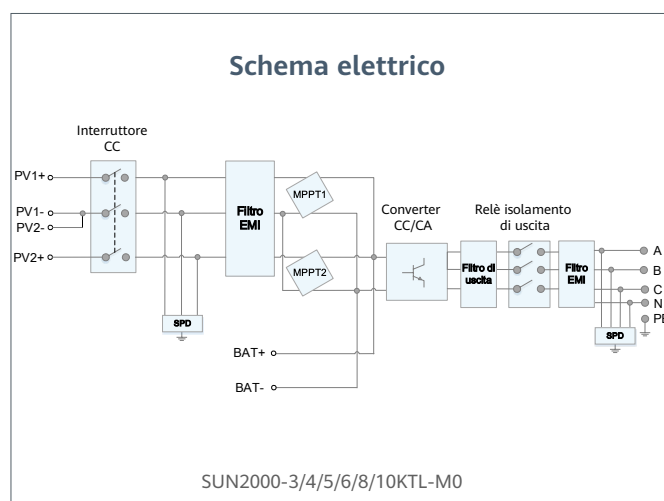
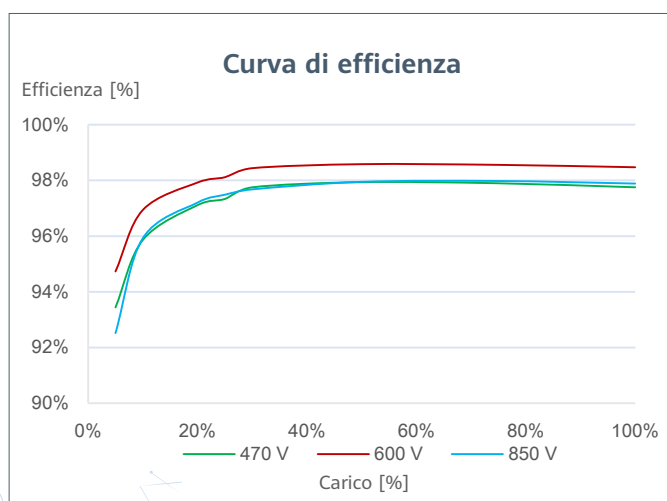

Sistema di gestione inverter NetEco 1000S



Intelligente

- Facile accesso ai dati sui dispositivi mobili
- Report proattivi di rendimenti e allarmi

Semplice

- Installazione e registrazione con un solo clic
- Allarmi di errore via e-mail

Stabile

- Gestione centralizzata
- Archiviazione dati fino a 25 anni

Struttura della rete

